

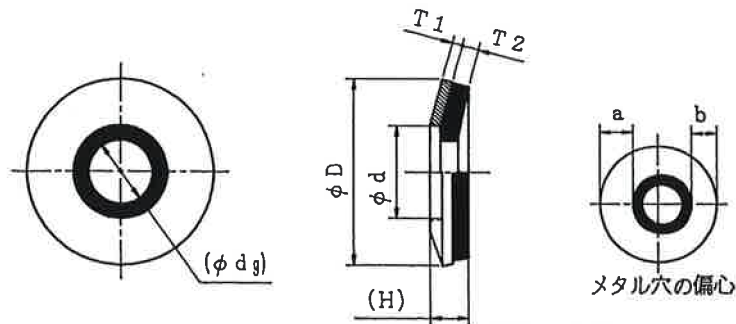

水漏れ防止座金仕様表



■品番：SBDW

■材質（金属部）：ステンレス鋼 ■材質（ゴム部）：ネオプレン、EPDM

呼び径	D	d	d_g	H	T_1	T_2	$(a-b)_{\max}$
M1	3.5 ± 0.1	1.1 ± 0.05	~ 0.8	1.5	0.5 ± 0.1	$0.7^{+0.4}_{-0.1}$	0.1
M1.2	4.5 ± 0.1	1.5 ± 0.05	~ 1.0	1.5	0.5 ± 0.1	$0.7^{+0.4}_{-0.1}$	0.2
M1.4	4.5 ± 0.1	1.5 ± 0.05	1.5~2.3	1.5	0.5 ± 0.1	$0.7^{+0.4}_{-0.1}$	0.2
M2.6	5.5 ± 0.15	3.0 ± 0.1	1.8~2.3	1.5	0.5 ± 0.1	$0.7^{+0.4}_{-0.1}$	0.2
M3	9.5 ± 0.2	4.0 ± 0.2	1.8~2.7	3.5	1.0 ± 0.1	1.7 ± 0.3	0.3
M4	9.5 ± 0.2	5.0 ± 0.2	2.7~3.6	3.5	1.0 ± 0.1	1.7 ± 0.3	0.3
M5	12.5 ± 0.2	6.0 ± 0.25	3.6~4.5	3.7	1.0 ± 0.1	1.7 ± 0.3	0.36
M6	14 ± 0.2	7.0 ± 0.25	4.5~5.6	4.1	1.0 ± 0.1	1.7 ± 0.3	0.36
M6	16 ± 0.2	7.0 ± 0.25	4.5~5.6	4.1	1.0 ± 0.1	1.7 ± 0.3	0.36
M8	18 ± 0.2	9.0 ± 0.3	6.0~7.5	4.1	1.0 ± 0.1	1.7 ± 0.3	0.42
M8	19 ± 0.2	9.0 ± 0.3	6.0~7.5	4.3	1.0 ± 0.1	1.7 ± 0.3	0.42
M10	16 ± 0.2	11.0 ± 0.35	7.7~9.4	3.5	1.0 ± 0.1	1.7 ± 0.3	0.36
M10	22 ± 0.25	11.0 ± 0.35	7.7~9.4	4.3	1.0 ± 0.1	1.7 ± 0.3	0.42
M12	25 ± 0.3	12.7 ± 0.35	9.2~11.3	4.3	1.0 ± 0.1	1.7 ± 0.3	0.42
M16	$32^{0}_{-0.6}$	17.0 ± 0.35	14.5~15.4	4.3	1.0 ± 0.1	1.7 ± 0.3	0.42
M20	$32^{0}_{-0.6}$	$21^{0}_{-0.5}$	19.0~	3.9	1.0 ± 0.1	1.7 ± 0.3	0.42